

Estimation of State of Charge (SoC) Using Modified Coulomb Counting Method with Open Circuit Compensation for Battery Management System (BMS)

Puspita Ningrum

Department of Electrical Engineering
Politeknik Elektronika Negeri Surabaya
Surabaya, Indonesia
puspitan62@gmail.com

Novie Ayub Windarko

Department of Electrical Engineering
Politeknik Elektronika Negeri Surabaya
Surabaya, Indonesia
ayub@pens.ac.id

Suhariningsih

Department of Electrical Engineering
Politeknik Elektronika Negeri Surabaya
Surabaya, Indonesia
nuning@pens.ac.id

Abstract—Battery is one of the important components in the development of renewable energy technology. This paper presents a method for estimating the State of Charge (SoC) for a 4Ah Li-ion battery. State of Charge (SoC) is the status of the capacity in the battery in the form of a percentage which makes it easier to monitor the battery during use. Coulomb calculations are widely used, but this method still contains errors during integration. In this paper, SoC measurement using Open Circuit Voltage Compensation is used for the determination of the initial SoC, so that the initial SoC reading is more precise, because if the initial SoC reading only uses a voltage sensor, the initial SoC reading is less precise which affects the next n second SoC reading. In this paper, we present a battery management system design or commonly known as BMS (Battery Management System) which focuses on the monitoring function. BMS uses a voltage sensor in the form of a voltage divider circuit and an ACS 712 current sensor to send information about the battery condition to the microcontroller as the control center. Besides, BMS is equipped with a protection relay to protect the battery. The estimation results of the 12volt 4Ah Li-ion battery SoC with the actual reading show an error of less than 1%.

Keywords—battery management system, modified coulomb counting, state of charge

I. INTRODUCTION

Increasing technological developments followed by the increasing demand for energy in line. This also came with an increase in population growth in the world. The source of electrical energy that comes from fossils is a non-renewable energy source. So that at this time, many companies are competing to carry out research and production in the field of renewable energy. To support these energy providers, energy storage is important to provide a reliable and continuous supply in a relatively long time, one of which is the battery.

Batteries are an important component in the current development of renewable energy which is commonly used as a storage medium for electrical energy. Where batteries are often encountered in electrical vehicles, power plants, and devices that require batteries [1] because they can be easily moved from one place to another when used at any time.

Battery monitoring is necessary to find out how the performance and condition of the battery used. Several factors affect battery performance including capacity and

energy output. For example, when compared to a new battery, the battery's stored capacity will decrease, this is due to the influence of temperature and long storage time. From the factors that have been described, an idea emerged to make a device that can monitor battery performance to minimize the decline in battery performance. Things that need to be considered when monitoring is voltage, charging, and discharging status [2].

The system created in this paper aims to design a battery monitoring system to estimate the State of Charge for a battery that has a 12volt 4Ah lithium type. Estimated State of Charge (SoC) is one of the most important problems in battery consuming applications [3]. The method of Coulomb Counting is widely used. But in this method, there are still errors during integration [4]. The modified Coulomb counting method used is Open Circuit Voltage (OCV) with OCV data retrieval using multiple constant current tests. The OCV method is done by measuring the difference in electric potential between two battery terminals at no load which is directly proportional to the battery capacity [5] [6]. Estimation of State of Charge (SoC) with Open Circuit Voltage is considered accurate, but cannot be applied to battery applications connected in series [7]. The battery monitoring system that will be designed can display measurements of State of Charge, voltage, current, Wh (Watt-hour), and Ah (Ampere hour) via the LCD and can record data that can be stored so that it can be viewed at any time by the user. It is also equipped with a protection system to keep battery usage in ideal condition, by cutting the power flow connected to the battery in case of over-voltage, under-voltage, and over-current during charge and discharge.

II. METHODS

A modified coulomb counting method with open circuit compensation for battery management system (BMS) would be implemented to this research. It has been equipped with a buck converter as a charging system. Then, it would be explained in the following points.

A. Coulomb Counting Method

The Coulomb Counting method is a method that can be used to calculate the electric charge (*coulomb*) that enters or leaves the battery so that this method can determine the value of the capacity that is in the battery. Electric current is generated from several electric charges moving per unit time (seconds). The equation for calculating SoC is shown

by equations (1) and (2) where SOC_0 represents the initial SoC, I_{bat} represents the current through the battery and Q_{rated} is the nominal capacity of the battery [8]. In general, the Coulomb Counting method is formulated as follows:

$$SOC = SOC_0 + \frac{\int_{t_0}^{t_0+t_n} I_{bat} \Delta\tau}{Q_{rated}} \times 100 \quad (1)$$

$$SOC = SOC_0 - \frac{\int_{t_0}^{t_0+t_n} I_{bat} \Delta\tau}{Q_{rated}} \times 100 \quad (2)$$

Annotation:

SOC = state of charge / battery percentage

SOC_0 = state of charge on the first second

I bat = current entering or leaving the battery

Q rate = total capacity on battery (Ah)

B. Open Circuit Voltage

The battery SoC estimation technique with Open Circuit Voltage (OCV) is one of the SoC estimation methods. Open circuit voltage is the voltage in an open circuit that is not connected to the load [8]. Open circuit voltage represents the full source voltage because there is no voltage drop to the load or because the voltage is not shared with the load.

OCV is a voltage condition when the voltage source is not connected to the circuit or the load.

The voltage at no load is the true voltage. Therefore, to get an accurate SoC estimation result, the battery must rest (rest time) to reach a state of cell balance before measuring the OCV of the battery or, it can be said that the battery state must be completely at no load. The output of the OCV method is a battery State of Charge (SoC) estimation value which can be used as a reference for measuring battery capacity.

C. Block Diagram System

A 12volt 4Ah lithium-ion battery was used in this study with an overview of how the system works is shown in Figure 1. The system is designed to keep the battery used in an ideal state so that the battery is not easily damaged.

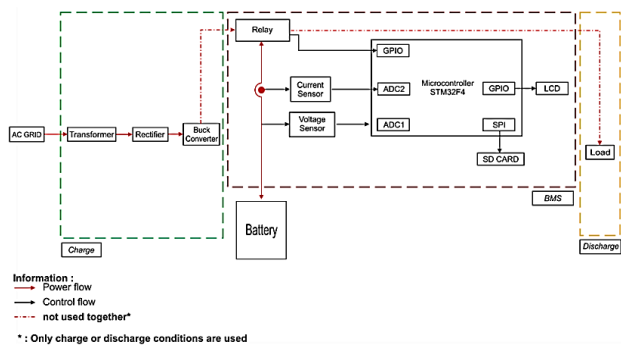

Fig. 1. Block diagram of the system

In this research, the battery is designed using the STM32F4 microcontroller as the control center. Voltage and current sensors as indicator readers of the battery state, which can be seen in Figure 2.1. In the design of this BMS tool, it can display the parameters on the battery, namely the value of battery voltage, State of Charge (SoC), Ah (ampere-hour), and Power (watts), where the SoC

estimation uses the Modified Coulomb Counting method. displayed on the LCD screen. As for battery protection, replay protection is used to protect the battery when it is over-current, over-voltage, and under-voltage, which will automatically cut off the current.

D. Flowchart of Research

The coulomb calculation method is done by measuring the charge that is covered by the battery at its current state when charging or discharging. However, there are some inefficiencies when using this method, due to the insecure conditions of the initial SoC reading [9]. An improved coulomb counting calculation method using open circuit compensation is required to determine the initial SoC to have a maximum SoC value of 100%. The algorithm flowchart can be seen in figure 2.

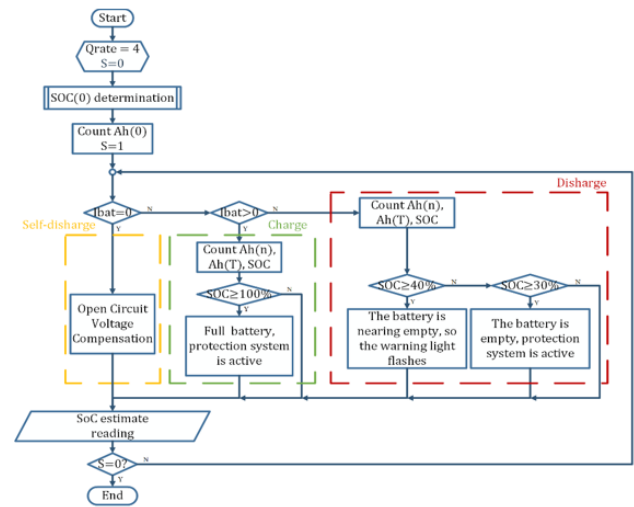

Fig. 2. Flowchart of the system

Estimates of the SOC of a Li-ion battery, in this case, a method based on monitoring the voltage and current. When the battery is in an open circuit, $I_{bat} = 0$ and compensation for losses when self-discharge, so the amount of charge lost in the open will be recalculated. With this method, the SoC value of the battery can still be read accurately and is not affected by the charger voltage when the battery is connected to the charger and the voltage drop when the battery is connected to the load. The principle and workflow of the modified coulomb counting algorithm with open circuit compensation can generally be seen in Figure 2, it can be seen that there are two initializations, namely battery voltage, and battery current, and there are three conditions on the battery, namely discharge, charge, and self-discharge. Where SOC_0 represents the initial SoC, I_{bat} represents the current passing through the battery and Q_{rated} is the nominal capacity of the battery, while S is the switch condition to determine whether the system is active or not. By determining SOC_0 , it is obtained from the Open Circuit Voltage (OCV) test with multiple constant current tests, so that the SOC_0 reading is more precise because if the SOC_0 reading only uses a voltage sensor, the SOC_0 reading is less precise which affects the next nth SOC_0 reading which is used for know the SoC when the battery is charging or discharging.

E. Battery Parameter Planning

This paper uses a Li-ion type battery. The battery in this system will be used in 2 conditions, namely charge and discharge. The usage of the battery is not immediately used in these 2 conditions but used to interchangeably in only 1 condition. Haijiu HJTX5L-FP-SIN Li-ion battery (12V, 4Ah) used as an object in this research. The specifications are as follows: max voltage = 13.9V (100%), min. voltage = 11.9V (30%), fast current charging = 6A, max. current discharging = 4A (1C), max. temperature = 60°C.

F. Buck Converter

The buck converter has the role of controlling the voltage from the rectifier output which is the grid source rectifier for charging the Haijiu HJTX5L-FP-SIN Li-ion battery. The buck converter consists of several main components, namely the mosfet as a switch, inductor, capacitor, and diode. Figure 3 is a Buck converter hardware. A specifications are as follows: $V_{in} = 32.24V$, $V_{out} = 14.4V$, $P_{out} = 17.28W$, $f = 40kHz$, $I_o = 1.2 A$.

1) Duty cycle:

$$D = \frac{V_{out}}{V_{in}} = \frac{14.4}{32.24} = 0.446 = 44.6\%$$

2) Rated Load Current:

$$I_L = I_o = \frac{V_{out}}{R} = 1.2A$$

$$R = \frac{V_{out}}{I_o} = \frac{14.4}{1.2} = 12 \Omega$$

3) Ripple Current:

$$\Delta I_L = 20\% \times I_L = 0.2 \times 1.2 = 0.24 A$$

4) Inductor Value:

$$L = \left[\frac{1}{f} \right] \times (V_{in} - V_{out}) \times \left[\frac{V_o + V_f}{V_{in} + V_f} \right] \times \frac{1}{\Delta i_L}$$

$$= \left[\frac{1}{40k} \right] \times (32.24 - 14.4) \times \left[\frac{14.4 + 0.7}{32.24 + 0.7} \right] \times \frac{1}{0.24}$$

$$= 864.88 \mu H$$

5) Maximum and Minimum Inductor Current:

$$I_{max} = I_L + \frac{\Delta I_L}{2} = 1.2 + 0.12 = 1.32A$$

$$I_{min} = I_L - \frac{\Delta I_L}{2} = 1.2 - 0.12 = 1.08A$$

6) Inductor RMS Current:

$$I_{L_{rms}} = \sqrt{I_L^2 + \left(\frac{\Delta I_L}{\sqrt{3}} \right)^2} = \sqrt{(1.2)^2 + \left(\frac{0.12}{\sqrt{3}} \right)^2} = 1.2A$$

7) Capacitor Value:

$$C_o = \frac{\Delta Q}{\Delta V_o} = \frac{\Delta i_L \times T}{8 \Delta V_o} = \frac{\Delta i_L}{8 \times f \times \Delta V_o} = \frac{0.24}{8 \times 40kHz \times 0.0144}$$

$$= 52.0833 \mu F$$

$$\Delta V_o = \frac{\Delta Q}{C_o} = \frac{\Delta i_L \times T}{8 C_o}$$

$$\text{Where } \Delta V_o = \pm 0,1\% \times V_{out}$$

$$\Delta V_o = 0.001 \times V_{out} = 0.001 \times 14.4$$

$$\Delta V_o = 0.0144 \text{ volt}$$

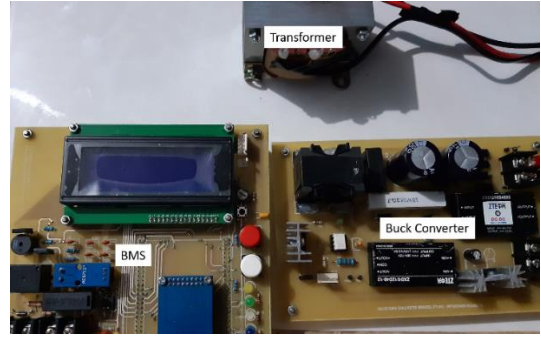

Fig. 3. Hardware BMS and charging

G. Open Circuit Voltage Test with Multiple Constant Current Tests

The open-circuit voltage test with multiple constant current tests is used to obtain parameter data in the form of current, voltage, and time when the open-circuit voltage is used to determine the OCV - SoC relationship on a Li-ion battery. This test is performed using the charge constant current method [10]. From the test results, it is then used to determine the SoC estimation using the modified Coulomb counting method with open circuit compensation. The data retrieval test is shown in Figures 4 and 5.

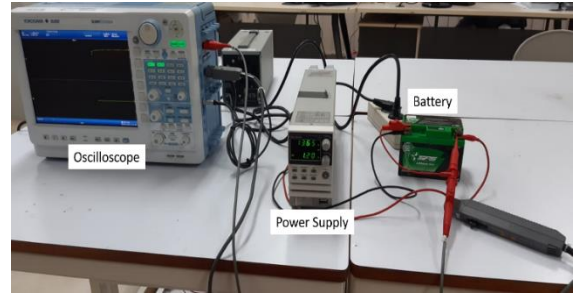

Fig. 4. Testing of battery characteristics data retrieval in charging conditions

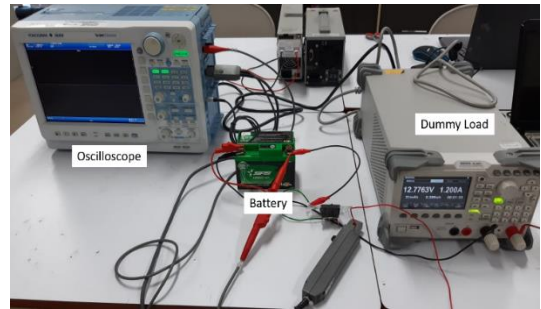

Fig. 5. Testing of battery characteristics data retrieval on discharging conditions

Figures 4 and 5 are tests when performing multiple constant current tests, the battery is charged or discharged with a current of 0.3C, namely 1.2A. In the battery charging condition, the first thing to do is to empty the Li-ion battery cell from the minimum battery voltage of 11.9 volts and charge it to the maximum battery voltage of 13.9 volts to record the charging time. Next, the battery is again discharged to a minimum voltage and recharged again by dividing the charging time that has been done into 10 pulses with a rest time or the battery's open-circuit condition for 1 hour. So that the battery is filled every 10% SoC interval from 0 - 100% SoC which is rested or in an open circuit for

1 hour. It is done until the highest cut-off voltage is reached until the SoC is considered to be 100%, namely 13.9 volts. This also applies to the battery discharge condition which is also discharged every 10% SoC interval. Then, the battery is rested or is in an open circuit for 1 hour until the lowest cut-off voltage is reached until the SoC is considered to be 0%. From the multiple constant current tests for charging and discharging the battery, the OCV-SoC curve of the Li-ion battery is obtained which can be seen in the figure below.

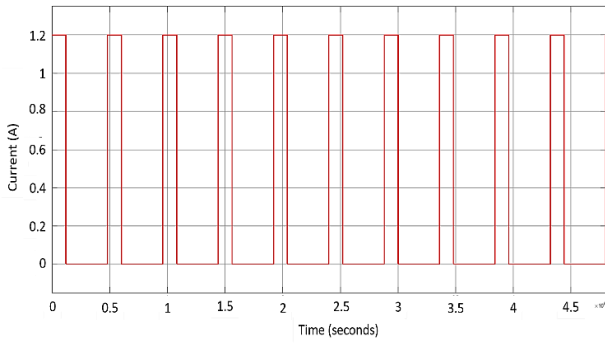

Fig. 6. Charging current pulses

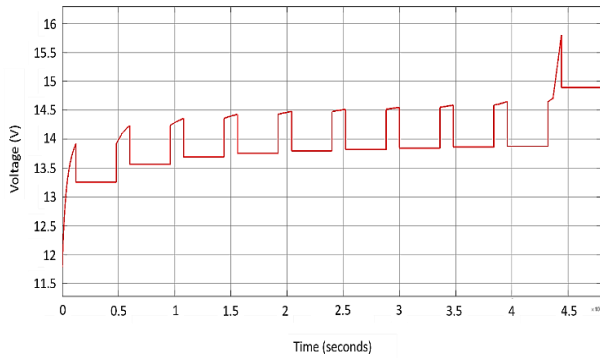

Fig. 7. Charging voltage pulses

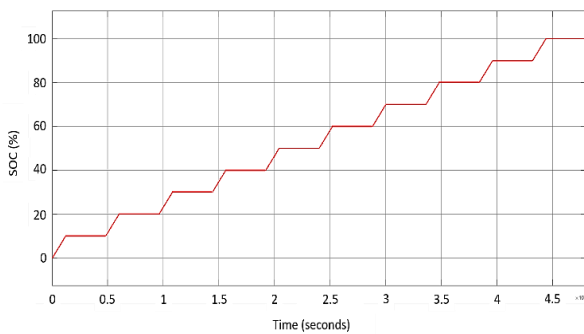

Fig. 8. SoC pulses top up

In Figure 6 and Figure 7, it can be seen that in the results of the output of current pulses and voltage pulses. There is a high (up) condition that is taken during the charging condition, while the low condition (down) is the battery rest time condition. Figure 8 shows the SoC reading, where it can be seen that the SoC value increases with the length of the charging time. The charging process is carried out from 0% to 100% SoC.

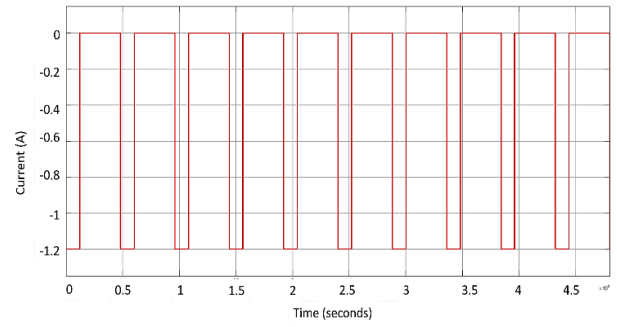

Fig. 9. Pulses discharging current

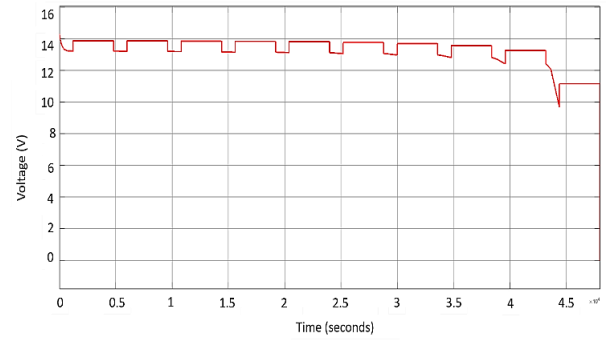

Fig. 10. Pulse discharge voltage

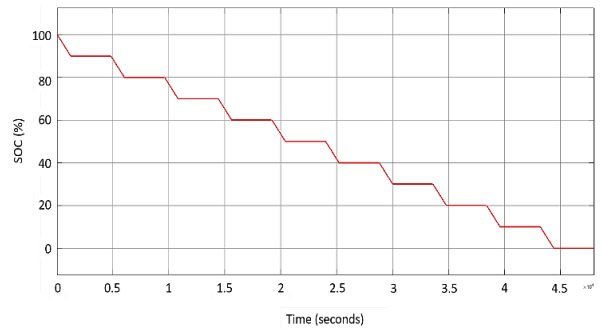

Fig. 11. Discharging SoC credit

In Figure 9 and Figure 10, it can be seen that in the results of the output of current pulses and voltage pulses, there is a low (decreasing) condition that is taken at the time or discharging condition. While the high condition (rising) is a battery rest time condition. Whereas in Figure 11 shows the SoC reading, where it can be seen that the SoC value decreases with the length of the discharging time. The discharging process is carried out from SoC 100% to 0%.

III. RESULTS AND ANALYSIS

After testing and taking actual data, multiple constant current tests are obtained and the parameters of current, voltage, charge, or discharge time are obtained. From this parameter, the SoC can be estimated using the modified Coulomb counting method with open circuit compensation which is then validated from the actual measurement data.

A. SoC Estimation

The estimation results of SoC using the modified Coulomb counting method with open circuit compensation can be seen in the graph below. Figure 12 shows the estimated SoC curve at the charge condition, while Figure

13 shows the estimated SoC curve at the discharge condition.

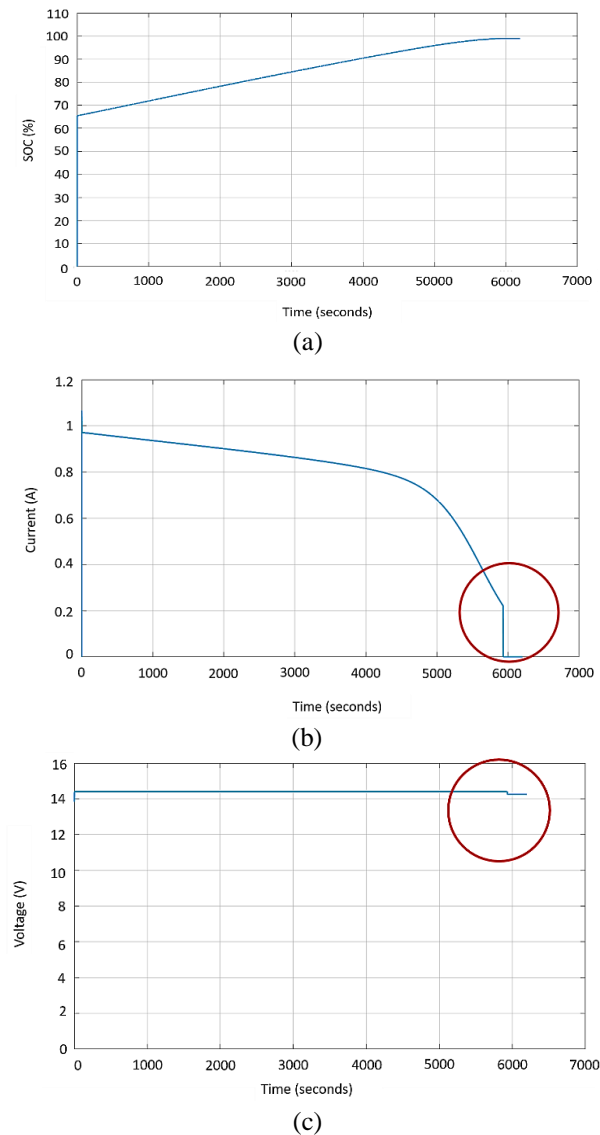

Fig. 12. Estimated SoC (a), charge current (b), charge voltage (c)

Figure 12 (a) is a graph of SoC estimation using the modified Coulomb counting method with open circuit compensation, which shows an increase in the graph due to increased battery capacity. The filling process is carried out from SoC 65% to SoC 100%. Figure 12 (b) is a graph of the flow during the charging process. Where, if viewed based on the area shown by the red circle, it is a condition when the protection system is active due to the battery being full or when the SoC is 100% worth, the protection system is active to stop the charging process on the battery.

When the current value $i=0$ is the condition when the voltage compensation is open circuit, in which case the SoC will continue to be read. Whereas in Figure 12 (c) is a graph of the voltage during the charging process. The area indicated by a red circle indicates a cut-off event during the filling process.

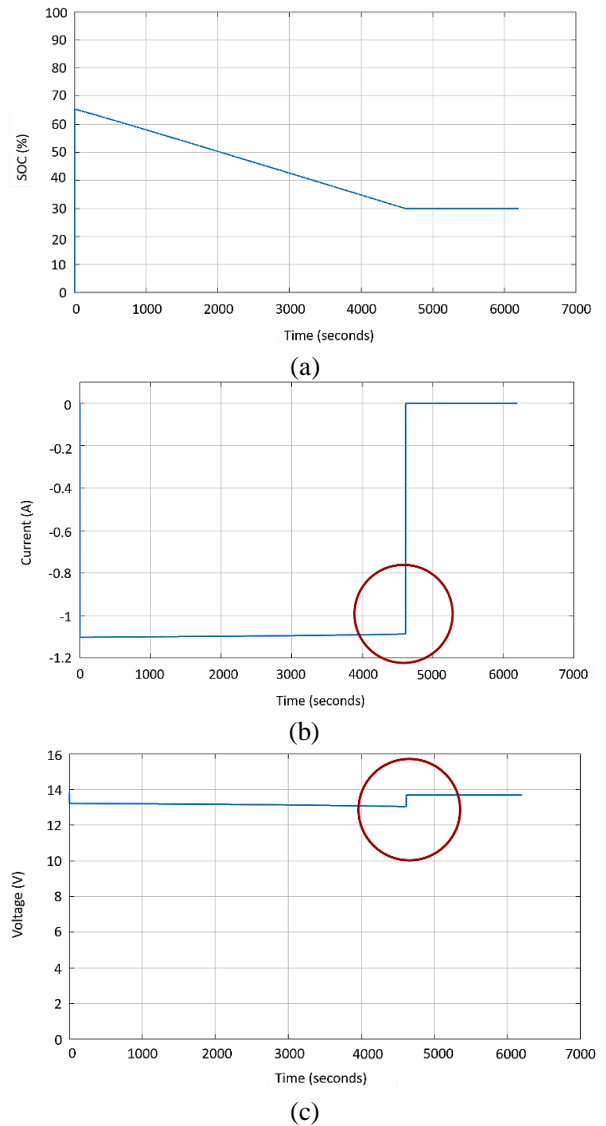

Fig. 13. Estimated SoC (a), discharge current (b), discharge voltage (c)

Figure 12 (a) is a graph of SoC estimation using the modified Coulomb counting method with open circuit compensation, which shows a decrease in the graph due to reduced battery capacity. The discharging process was carried out from SoC 65% to SoC 30%. Figure 13 (b) is a graph of the flow during the emptying process. Where if seen based on the area shown by the red circle, it is a condition when the protection system is active due to the battery being empty or when the SoC is 30% worth, the protection system is active to stop the discharge process on the battery.

When the current value $i=0$ is the condition when the voltage compensation is open circuit, in which case the SoC will continue to be read. Whereas in Figure 13 (c) is a graph of the stress during the discharge process. The area indicated by a red circle indicates a cut-off event during the emptying process.

The existence of a protection system that is active during the charge and discharge process can reduce the decrease in battery life and also keep the battery when used so that it remains in ideal condition or according to the datasheet.

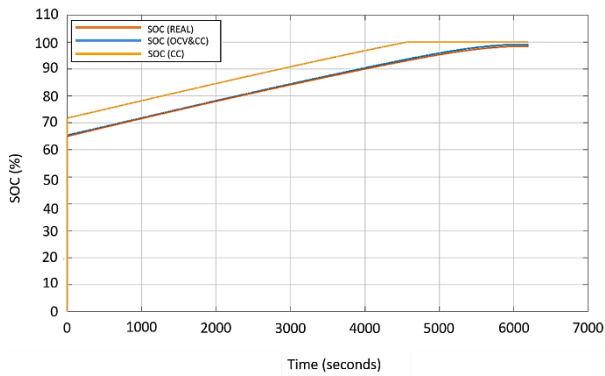

Fig. 14. SoC reading result at charging

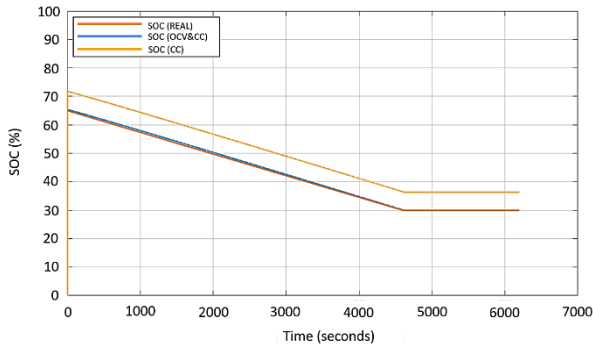

Fig. 15. SoC reading results at draining

Figure 14 shows the SoC reading when charging. From this figure, it can be seen that the reading of the modified Coulomb Counting method using Open Circuit Voltage (OCV) with the determination of SoC_0 is obtained from the Open Circuit Voltage (OCV) test with multiple constant current tests, so that the SoC_0 reading is more precise, because if the SoC_0 reading only uses the voltage sensor then the SoC_0 reading is less precise which affects the next nth SoC_0 reading which is used to determine the SoC condition of the battery when charging. Whereas in Figure 15 is the result of the SoC reading during discharge. It can be seen from the reading shown by the graph which is the result of the SoC reading using the modified Coulomb counting method with open circuit compensation coinciding with the SoC readings obtained from the multiple constant current tests. While the graph which is the result of reading the SoC using coulomb counting without modification there is an error, where if you see there is a large enough SoC reading error in coulomb counting without being compared to the modified Coulomb counting method with open circuit compensation.

IV. CONCLUSIONS

In the research of the SoC estimation method for Li-ion 12volt 4Ah battery using a modified Coulomb counting method with open circuit compensation, the error was below 1%. To get the actual battery voltage value, a battery test is carried out using multiple constant current tests with a rest time or a battery open circuit condition for 1 hour where each battery has different OCV characteristics so that the battery voltage level cannot be equalized between one battery and the battery that is used. different types. The existence of a protection system can reduce the decrease in a lifetime and keep the battery in ideal condition or according to the datasheet when used.

ACKNOWLEDGMENT

The authors wish to thank Departemen Teknik Elektro, Politeknik Elektronika Negeri Surabaya that has supported this research.

REFERENCES

- [1] Anggita Bayu, Dudi Darmawan dan Ahmad Qurthobi. "Perancangan Dan Implementasi Alat Ukur State Of Charge Sistem Pengawasan Pada Baterai Lead Acid Menggunakan Metode Open Circuit Voltage". Universitas Telkom. Jurnal e-Proceeding of Engineering. April 2017.
- [2] Andica Dian Isnaini, Suwandi, Reza Fauzi Iskandar Prodi S1 Teknik Fisika, Fakultas Teknik Elektro. "Estimation State Of Charge Of Lithium Ion Battery Using Coulomb Counting Method". Universitas Telkom. Jurnal e-Proceeding of Engineering. April 2017.
- [3] Kong Soon Ng, Chin Sien Moo, Yao Feng Huang, dan Yao Ching Hsieh, "An Enhanced coulomb counting for estimation state of charge and state of health of lead acid batteries". Elsevier. November 2009.
- [4] Novie Ayub Windarko and Jaeho Choi. "SOC Estimation Based on OCV for NiMH Batteries Using an Improved Takacs Model". Power Electronics Research Centre, Chungbuk National University. Maret 2010.
- [5] Alessandro Mariani, Thomas Stockley, Kary Thanapalan, Jonathan Williams, and Peter Stevenson, "Simple and Effective OCV Prediction Mechanism for VRLA Battery Systems," in Proceedings of the 3rd International Conference on Mechanical Engineering and Mechatronics, Prague, Czech Republic, Agustus 2014, p. No. 140.
- [6] M.Coleman, C.K Lee,WG Hurley. "State of health determination:two pulse load test for a vrla battery". Power Electronics Research Centre, National University of Ireland, Galway,Ireland. Mei 2017.
- [7] C. S. Moo, K. S. Ng, Y. P. Chen, Y. C. Hsieh. Department of Electrical Engineering, National Sun Yat-sen. " State Of Charge estimation with Open Circuit Voltage for Lead Acid Batteries". University, Kaohsiung, Taiwan Department of Electrical Engineering, National Dong Hwa University, Hualien 97401, Taiwan. Institute of Electrical and Electronics Engineers. Januari 2019 (IEEE).
- [8] I. Bacchouche, S. Jemmali, A. Mlaya, B. Manai and N. E. B. Amara, "Implementation of an Improved Coulomb-Counting Algorithm Based on a Piecewise SOC-OCV Relationship for SOC Estimation of Li-Ion Battery". Maret 2018.
- [9] Ines Baccouche, Asma Mlayah, dan Sabeus Jemmali, "Implementation of a Coulomb Counting Algorithm for SOC estimation of Li-Ion Battery for Multimedia Applications". International Multi-Conference on Systems, Signals and Device. Desember 2015.
- [10] Zhang, Ruifeng & Xia, Bizhong & Li, Baohua & Cao, Libo & Lai, Yongzhi & Zheng, Weiwei & Wang, Huawen & Wang, Wei & Wang, Mingwang, "A Study on the Open Circuit Voltage and State of Charge Characterization of High Capacity Lithium-Ion Battery Under Different Temperature," Energies, September 2018.