

Temperature and Humidity Control System for 20 kV of Cubicle with Multiple Input Multiple Output Fuzzy Logic Controller

Mochammad Berliano Putra Ramadhan
*Department of Electrical Engineering
 Electronic Engineering Polytechnic
 Institute of Surabaya
 Surabaya, Indonesia
 berliano12@pe.student.pens.ac.id*

Moh. Zaenal Efendi
*Department of Electrical Engineering
 Electronic Engineering Polytechnic
 Institute of Surabaya
 Surabaya, Indonesia
 zen@pens.ac.id*

Syechu Dwitya Nugraha
*Department of Electrical Engineering
 Electronic Engineering Polytechnic
 Institute of Surabaya
 Surabaya, Indonesia
 syechu@pens.ac.id*

Abstract—Cubicle 20 kV is crucial electrical equipment in the 20 kV power distribution system. Often, cubicle issues arise due to excessively low or high temperatures and humidity, which can lead to the presence of water spots and corrosion on the components inside the 20 kV cubicle. Temperature and humidity should be maintained in optimal conditions. To achieve this, a system is needed to control the temperature and humidity in the 20 kV cubicle. The system can monitor and control the temperature and humidity inside the cubicle by using a multiple-input and multiple-output fuzzy logic controller. The fuzzy input is temperature and humidity, while the output is the heater and exhaust fan activation angle. The system has successfully controlled temperature and humidity with a set point value of 35 °C and a humidity of 60% RH. This implementation of fuzzy multiple inputs and multiple outputs has performed well and resulted in only a small error of 0.55% for temperature and 1.05% for humidity. The designed device is able to condition the temperature and humidity according to the set point even if given interference. The system is able to lower the temperature of 38 °C to 35 °C and increase the humidity from 53% RH to 60% RH. With the presence of this device, the temperature and humidity in the cubicle 20 kV can be controlled according to the set point values specified, namely a temperature of 35 °C and a humidity of 60% RH.

Keywords— *corona, cubicle 20 kv, fuzzy logic, humidity, temperature*

I. INTRODUCTION

Energy consumption is a fundamental factor that supports the growth of the economy and directly or indirectly affects society and the workforce. Energy consumption and economic growth are closely linked [1]. If causality goes from energy consumption to economic growth, then this growth shows that an economy depends on energy [2]. Electric power is usually distributed from generating systems to distribution systems to provide reliable and cost-effective power supplies. Electric power reliability is the term used to measure the capacity of a system to supply a sufficient amount of electricity according to load requirements. Therefore, it is essential to ensure the level of reliability of the system in the event of a failure of electricity flow [3].

The 20 kV cubicle is an electrical energy distribution equipment found in the 20 kV grid. In the cubicle, there are connectors, or bus bars. Power connectors are essential elements of power systems therefore, it is essential to ensure

reliable performance and operation since failure of such components can cause significant power outages, resulting in major disasters and costly consequences [4][5]. Electrical resistance may be the best indicator of the quality of the power connector. Thus, electrical resistance is often used as an indicator of damage or an indicator of the feasibility of power connectors [6]. In addition to the problem of resistance to the connector, one of the disturbances that can occur in a 20 kV cubicle is when temperature and humidity conditions are high, resulting in the presence of water vapor clinging to the walls of the cubicle, which can cause corona discharge.

The corona occurs when the air around the conveyer or conductor is ionized, leading to charge release. The main cause of the corona is the appearance of electric field values around the conductor's surface [7][8]. Air pressure can also affect the onset of the corona, as the air pressure conditions become tighter, the average electron increases, and the air molecules in the surrounding space conductors are ionized more easily to produce corona discharge [9][10]. In such cases, it can cause air insulation failure and a short connection. Another impact that can also occur is corrosion. Corrosion is the degradation or damage of a metal material due to a chemical reaction between the metal and its environment. Corrosion generally occurs when the metal interacts with oxygen, water, or other chemical substances, which causes the metal to melt [11]. On copper plates, it is essential to maintain their surface condition, as a small amount of corrosion will cause damage and switching failure [12][13]. Therefore, in this paper, a system was created that could monitor and control temperature and humidity within the cubicles. With this device, it is expected that the temperature in the cubicle will be more stable and maintained, not exceeding 35°C for temperature and 60% RH for humidity. The measurement results from the sensor can be displayed on the LCD and sent directly to the website, making it easier for officers to monitor temperature and humidity conditions in 20 kV cubicles.

II. METHODS

This study aims to monitor and control temperature and humidity in 20 kV cubicles. The temperature and humidity control of the system uses the exhaust fan and heater by setting the exhaust fan speed and the heat of the heater, which are controlled by the fuzzy logic controller. The

ESP8266 is also used to monitor temperature and humidity through the website's system design.

Fig. 1 shows the block diagram of the prototype. The main components for this system are microcontroller STM32, DHT22 sensor, TRIAC, IC TCA785, and ESP8266.

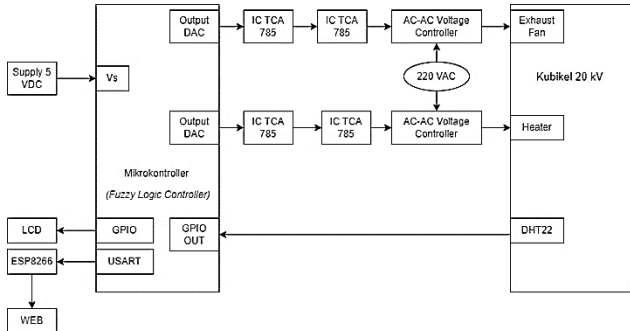

Fig. 1 System Design

A. System Modeling

1. Modeling of Cubicle Box 20kV

Testing of the system was carried out with 20 kV box cubicle replica media under the Schneider SM6-24. The size used is the real size. To obtain the volume of the cubicle, use the following equation:

$$\begin{aligned}
 V &= P \times l \times t \\
 &= 1,23 \text{ m} \times 0,75 \text{ m} \times 1,6 \text{ m} \\
 &= 1.476 \text{ m}^3
 \end{aligned}
 \tag{1}$$

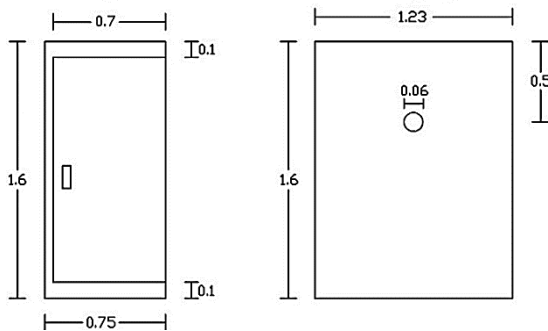

Fig. 2 Design Of Cubicle 20 kV

Fig. 2 represents the design of the cubicle used. The cubicle uses a medium made of iron plates that are processed according to the size of the original cubicle. In this cubicle, there is a heater and exhaust fan used to control the temperature and humidity inside when placed indoors. The manufacture of miniature cubicles refers to the IP42 (Ingress Protection 42) rating listed in the Schneider cubicle dataset. The use of ratings or IP codes is described in the IEC 60529 standard, which is used to mark the protection capability of a material product or electrical goods against external disturbances or impacts [14]. In the context of the design of cubicles in this article, IP42 means cubicles protected from tools and cables larger than 1 millimeter in size and protected from low-pressure water spray.

2. Calculation of the heater power

The heater is a component that will be controlled and undergo several settings related to its heating level. The higher the voltage supplied to the heater component, the higher the heat generated [14]. The function of the heater in this device is to increase the temperature inside the cubicle if the temperature decreases. The heater is placed at the base of the cubicle. The placement of this heater refers to a 20 kV cubicle, where the heater on the PLN cubicle is usually placed at the bottom. To calculate the heat capacity to be attached to the cubicle, the following equation is used:

$$m = \rho \cdot V \tag{2}$$

From the equation, we obtain the value of the air mass inside the cubicle. Furthermore, it is possible to find the value of the heat capacity using the equation.

$$Q = m \cdot C \cdot \frac{dT}{dt} \tag{3}$$

$$Q = [(1.476)(1.2)](1000) \frac{5}{60}$$

$$Q = 147.6 \text{ Watt}$$

From these calculations, the temperature difference is assumed to be 5°C with a change time of 1 minute, so that the heat capacity used is above 147.6 watts, which is 150 watts.

3. Calculation of the Cubic Meter Hour of Exhaust Fan

Exhaust fans in this device play a role in lowering the temperature inside the cubicle in the event of an increase in temperature by pulling or smoking air indoors and discharging it outdoors. To determine the exhaust fan capacity, it is necessary to know the CMH (cubic meter hour) value or indoor air circulation requirements. The volume of the designed cubicles is 1,476 m³.

The cubicles are a group of "factory" types with dynamic room and substation space. Therefore, the ACH used is worth 20. The following are the required CMH calculations:

$$\begin{aligned}
 \text{CMH} &= V \times \text{ACH} \\
 &= 1.476 \text{ m}^3 \times 20 \\
 &= 29.52 \text{ m}^3/\text{jam}
 \end{aligned}
 \tag{4}$$

The minimum CMH value for an exhaust fan is 29.52 m³/h. Therefore, in this system, exhaust fans are used on the market with a CMH capacity of 2.35 m³/min, or 141 m³/min.

4. Modeling Fuzzy Logic

Fuzzy logic controller (FLC) is a method of system control. Fuzzy logic in this device is responsible for controlling temperature and humidity in the 20 kV cubic box. In this paper, fuzzy control is used because it has high flexibility, is able to manage the number of input and output memberships according to the needs of the system, and has the ability to handle complex systems. Fuzzy controllers can control nonlinear process models, and model process delay times are significantly better than classical controllers [15].

Fuzzy logic controllers (FLC) have emerged as one of the most active and useful areas of research in the field of control. That's why fuzzy logic controllers have been successfully implemented to control various physical processes [16]. The fuzzy controller demonstrates the model using the IF-THEN rule in the form "if X and Y, then Z". The fuzzy inference system consists mainly of fuzzy rules, membership functions, and fuzzification and defuzzification operations. By applying fuzzy inference, regular crisp inputs produce a regular crisp output, which is easy to interpret and understand. Fuzzy controllers consist of simple rules such as : "if temperature is high and humidity is normal, then air conditioning is high", where temperature, humidity, and air conditioning are linguistic variables, height, and normal are linguistic values characterized by membership functions . There's a stage called fuzzification, database construction, rule-base determination, and defuzzification [17].

Multiple inputs and multiple fuzzy logic controllers mean that the input values on the fuzzy controller are more than one. Multiple outputs on mean output values controlled by fuzzy logic are more common than one. This paper shall be simulated and tested integrally using multiple input fuzzy logic outputs. Multiple inputs to the system are temperature and humidity, while the output is the exhaust fan trigger angle and the heater trigger angle.

a. Fuzzification

Fuzzification is the step of initially converting inputs into fuzzy forms or linguistic variables, which are then shown with each membership function as a fuzzy set. The system is equipped with multiple inputs and outputs (MIMO). The inputs are temperature and humidity, while the outputs are the heating and fan winding angle values. Two trapezoids and three triangles make up the membership function. Fig. 3 displays the membership operations applied in this system.

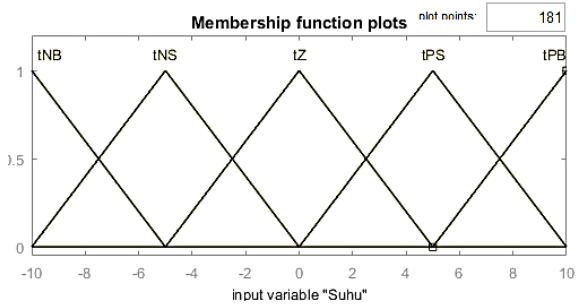

(a)

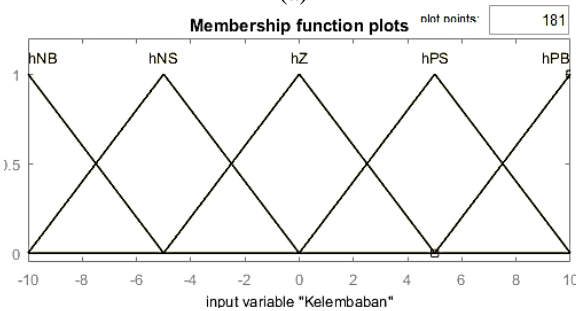

(b)

Fig. 3 Variable Input Temperature (a), Variable input Humidity (b)

Fig. 3 shows the formation of a fuzzy input set divided into two sets, namely a temperature set and a moisture set. The temperature input set is divided into 5 sections, including tNB (temperature Negative Big), tNS (temperature Negative Small), tZ (temperature Zero), tPB (temperature Positive Big), and tPS (temperature Positive Small). The humidity input set is divided into five parts: hNB (humidity Negative Big), hNS (humidity Negative Small), hZ (humidity Zero), hPB (humidity Positive Big), and hPS (humidity Positive Small). Values from -10 to 10 indicate the difference between the specified set of points. So -10 means the current temperature is 25°C.

b. Rule Base

The output of fuzzy logic results in a trigger angle value that is adjusted to the setpoint. By taking into account the temperature and humidity values utilized as fuzzy input variables, the basis of the rule may be established. The rule base is used to determine the required control based on the plans that the operator has already developed. In fuzzy logic, the Takagi Sugeno Kang method, also referred to as the Sugeno Method, uses the IF-THEN rule, and the results or consequences of the system are represented in the form of fixed values or linear equations rather than fuzzy sets. Table I shows the basis of the rules used in this study.

TABLE. I RULE BASE OF FUZZY MULTIPLE INPUT MULTIPLE OUTPUT

		Temperature				
		tNB	tNS	tZ	tPS	tPB
H u m i d i t y	hNB	EF=M H=H	EF=M H=H	EF=M H=M	EF=M H=W	EF=F H=W
	hNS	EF=S H=H	EF=S H=M	EF=S H=W	EF=M H=W	EF=F H=W
	hZ	EF=S H=H	EF=S H=M	EF=S H=W	EF=M H=W	EF=F H=W
	hPS	EF=S H=H	EF=S H=M	EF=S H=M	EF=M H=M	EF=F H=M
	hPB	EF=S H=H	EF=S H=H	EF=S H=H	EF=M H=H	EF=F H=H

Description :

EF = Exhaust Fan

H = Heater

Input

PS = Positive Small

NS = Negative Small

PB = Possitive Big

NB = Negative Big

Z = Zero

Output

M = Medium

H = Hot

S = Slow

W = Warm

F = Fast

Table I shows that the base rule on fuzzy design has 25 rules. Each base rule has two outputs: the exhaust fan (EF) and the heater (H). Output is categorized into two

categories: output for exhaust fan loads and output for heater loads. The output of the exhaust fan on the rule base is quoted as slow, medium, and fast. The output heater on the base rule is classified as warm, medium, and hot. The input is divided into two part: temperature and humidity. On each membership temperature input, the letter "t" is added, while on the membership input humidity, the letter "h" is added. The rule is based on trial and error. In the process of determining the base rule, an adjustment was made based on the results of the hardware test.

c. Defuzzification

Defuzzification is necessary to transform the fuzzy values (linguistic variables) from the rule base's output values, which are still fuzzy, which are then transmitted to the system. This system employs a weighted average defuzzification technique. This approach prunes any output membership function that is greater than the limit set by each fuzzy output. The single value of the output is mixed with the average weight of the output when using the weighted average defuzzification method. In the system, there are two outputs, the defuzzification process is performed twice, on the heater trigger angle output and the exhaust fan trigger angle output. The membership function used in this system is shown in Fig. 4.

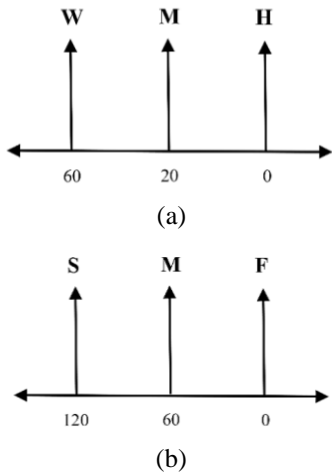

Fig. 4 Variable Output Heater (a), Variable Output Exhaust Fan (b)

III. RESULTS AND DISCUSSION

This simulation's goal is to evaluate the effectiveness of previously-created fuzzy controls. This simulation was performed using Matlab software. The series of simulations is shown in Fig. 5.

In this simulation, a close loop is performed. The inputs of fuzzy control are temperature and humidity, while the outputs are exhaust fans and heaters. The set point for temperature is 35°C, and for humidity, the set point is 60% RH. The output value resulting from the fuzzy control will be feedbacked so that it will generate an error value. The error value is used as a fuzzy control input. The simulation is divided into one main sequence and two subsequences, the designed fuzzy control series and the AC-AC voltage control series for the heater and exhaust fans.

In simulations, there is a program to relate the amount of heat and exhaust fan voltage to the temperature and humidity values. The program is shown in Fig. 6.

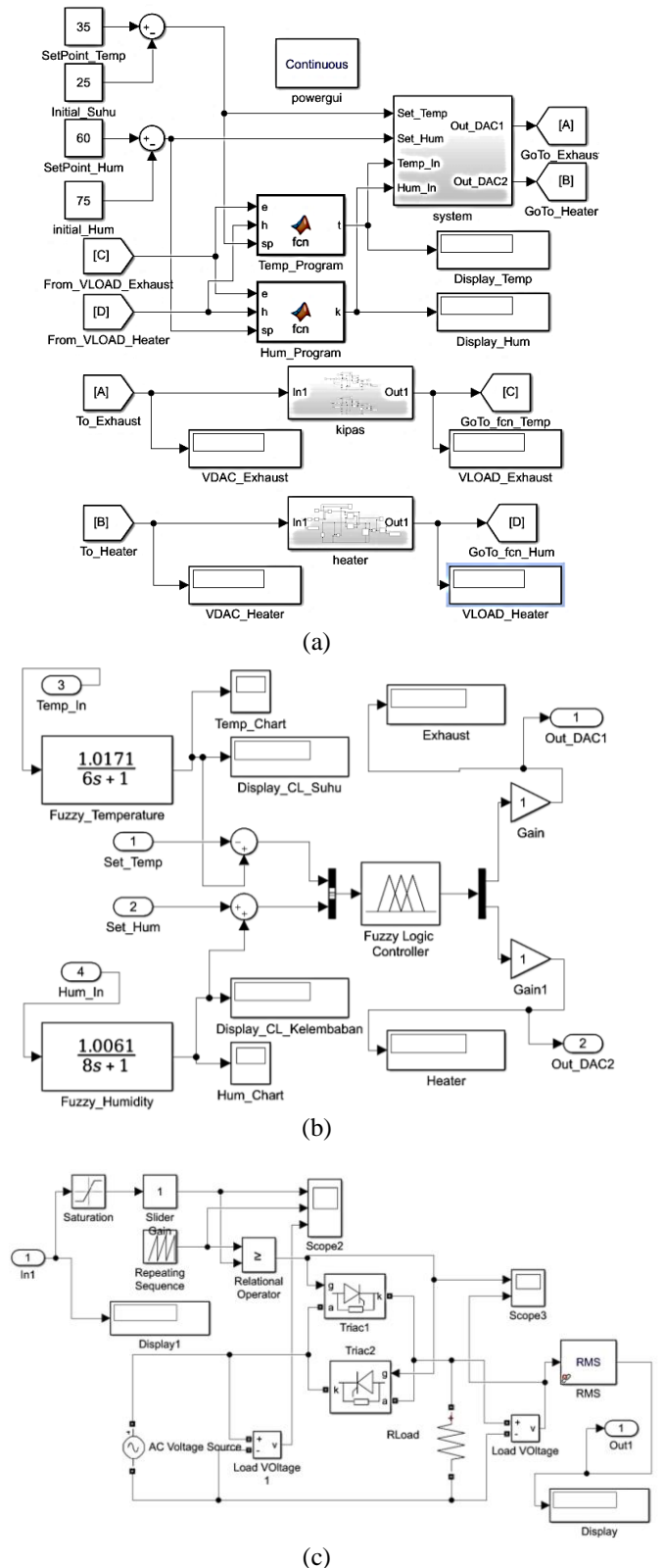

Fig. 5 Main Simulation Circuit (a), AC-AC Voltage Circuit (b), Control Circuit (c)

Fig. 6 shows the program block on the system. A value of 0.2 is obtained by assuming that every 10 volts on the exhaust fan can increase humidity by 2% RH and every 10 volts on the heater can increase temperature by 2 °C. The program was designed so that simulations could approach the original conditions, where temperature and humidity were inversely proportional.

```

Editor - Block SimulasiMatlabPaper_Berliano/Temp_Program*
Temp_Program* x +
1 function t = fcn(e,h,sp)
2 t = sp - 0.2*e + 0.2*h;
    
```

(a)

```

Editor - Block SimulasiMatlabPaper_Berliano/Hum_Program*
Temp_Program* x Hum_Program* x +
1 function k = fcn(e,h,sp)
2 k = sp + 0.2*e - 0.2*h;
    
```

(b)

Fig. 6 Program Block Temperature (a), Program Block Humidity

The value of the transfer function is obtained through open loop (without control) testing, which aims to determine whether the converter is capable of reaching the specified set point and the length of time the system has spent getting there. The open loop test results are shown in Table II.

TABLE. II Open Loop Hardware Test Results

Time (Min)	Temp HTC (°C)	Sensor Temp (°C)	Hum HTC (%RH)	Sensor Hum (%RH)	Temp Error (%)	Hum Error (%)
0	29.7	29.68	79.9	78	0.0033	0.0237
8	32.6	32.5	78.1	76	0.0030	0.0268
16	34.4	34.6	73.4	71.2	0.0058	0.0299
24	35.3	35.3	69.7	67.4	0	0.0329
32	35.4	35.5	63.8	6.4	0.0028	0.0253
40	35.6	35.5	61.2	60.5	0.0028	0.0105

Table II shows the heat of the temperature when the steady state is 35.6 °C (DHT 22 temperature sensor reading). The steady-state humidity is 60.5% RH (DHT temperature sensor reading 22), with a transient length of time of 1800s or 30 min. So the value of τ_s is obtained by the equation:

$$TS = 5\tau \tag{5}$$

$$1800 = 5\tau$$

$$\tau = 360$$

The gain value of the response output is obtained using the equation:

$$K = \frac{Y_{ss}}{X_{ss}} \tag{6}$$

With Y_{ss} being the steady state value and X_{ss} being the set point, the output of the temperature response gain value is 1,0171, while the output gain of the humidity response is 1,0061. Once the gain value is obtained, the following modification of the transfer function:

$$\frac{C(s)}{U(s)} = \frac{K}{\tau s + 1} \tag{7}$$

$$tf Hum = \frac{1.0061}{360s + 1}$$

$$tf Temp = \frac{1.0171}{360s + 1}$$

Simulation will be a reference in the design of fuzzy controls to be applied to hardware. Transfer function values are included in the simulation series. An important point to note is the time it takes to reach a steady state. The total simulation time is 40 minutes. Initial condition settings according to the temperature and humidity conditions within the cubicle in real terms. Simulation results are shown in Table III.

TABLE. III Simulation Result

	Set Point	Close Loop	Initial Condition	Rise Time (s)	Error Close Loop
Temperature	35 °C	34.85 °C	25 °C	300	0.42 %
Humidity	60 %RH	60.25 %RH	75 %RH	900	0.41 %

Table III shows a close loop simulation result with fuzzy logic, multiple inputs and multiple outputs. The rise time temperature in the simulation was 300 s, or for 5 minutes. And the simulated humidity rise time is 900 s, or 15 minutes. Longer set points of humidity were achieved due to the fuzzy design that focuses on temperature control. The precipitation due to humidity below 90% RH can be said to be safe, according to the cubic Schneider dataset. Simulation is performed by giving the set point values to each input, there is an initial condition used as a comparison of the set point values. Determination of initial conditions based on the temperature and humidity of the chamber inside the 20 kV cubicle. The initial condition of temperature is set at 25 °C, while the initial condition of humidity is 75% RH. So the graph shows the difference in set point values and initial conditions. The following is a graph of the simulation results close to the loop shown in Fig. 7.

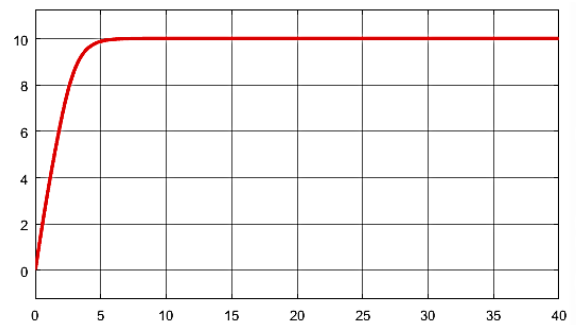

(a)

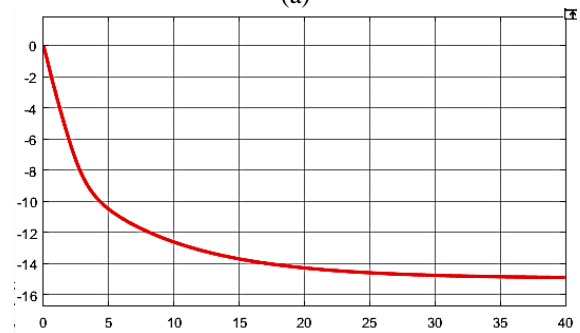

(b)

Fig. 7 Temperature Chart (a), Humidity Chart (b)

Figure 7 shows a temperature chart and a humidity chart. The value means that the fuzzy control has successfully increased the temperature by 10 °C. This is due to the fact that the difference in the set point value of the temperature with the initial temperature is -10, so it is necessary to increase 10 °C. On the humidity chart to reach the steady value of -15. The value means that the fuzzy control has successfully reduced the humidity by 15% RH. This is due to the difference in the value of the moisture set point with the initial value of +15, so a reduction of 15% RH is necessary. The close loop simulation error value is relatively small, namely 0.42% error for temperature and 0.41% error for humidity. The error value may be due to the gain value of a transfer function that is not equal to 1 or an ideal condition.

Integration testing with controls was also performed using hardware, which was applied to previously designed cubicle box media. The heater and exhaust fan are inserted into the cubicle box with the lay as shown in Fig. 8.

Fig. 8 shows the DHT22 sensor placement between the heater and exhaust fan. The exhaust fan position is above because the hot air moves upward, so in the event of overheating, the exhaust fan can act as a hot air exhaust and maintain air circulation. The tooling is placed on the outside of the cubicle. Testing was performed using 220 Volt sources. The following is an integration test shown in Fig. 9.



Fig. 8 Placement of Heater and Exhaust Fan

Fig. 9 Shows the placement of the bearing device at the bottom. Heater load wires and exhaust fans will enter through the holes at the bottom of the cubicle. It required two 220 Volt sources for the system to run, the first for the Hi-Link as a microcontroller source and the ESP8266. And the young one is for the AC-AC voltage controller circuit. The test was conducted in the afternoon with an initial temperature of 29.7 °C and a humidity of 75.4% RH. The results of the test are shown in Table IV.



Fig. 9 Integration Test

Table IV shows the results of integration testing with fuzzy controls. Testing lasted 20 minutes. HTC-2 is used as a temperature and humidity comparator. The set of temperature points can be reached in the 10th minute and with a value of 35.2 °C, the temperature condition will tend to be constant until the 15th minute. Meanwhile, the set of humidity points can be reached in the 12th minute, but in the 15th minute, the humidity drops and is constant with a value of 58% RH. This shows that the system has not been able to reach the set point expected to be perfect. But it still has an error. Generally, the DHT22 sensor reading with HTC-2 measuring instruments has an average temperature error of 0.55% and an average humidity error of 1.05%. To clarify the results of the system test integrated with the control, the test results are also validated through the graph shown in Fig. 10.

TABLE. IV Integration Test Result

Time (Min)	Temp Sensor (°C)	Hum Sensor (%RH)	Temp HTC (°C)	Hum HTC (%RH)	Temp Error (%)	Hum Error (%)
0	29.7	75.4	29.9	76.8	0.67	1.82
1	29.8	74.8	30	75.4	0.67	0.80
2	30	74	30.2	74.7	0.66	0.94
3	30.6	73.6	30.9	74	0.97	0.54
4	31.5	72.9	31.4	73.5	0.32	0.82
5	32.3	70.3	31.9	71.8	1.25	2.09
6	32.7	68.7	32.4	69.8	0.93	1.58
7	33.5	66	33.3	66.8	0.60	1.20
8	34	64.6	33.6	65.8	1.19	1.82
9	34.6	62.2	34.3	63.4	0.87	1.89
10	35	61.7	34.7	62.8	0.86	1.75
11	35.2	60.4	35	60.8	0.57	0.66
12	35.4	60	35.2	59.5	0.57	0.84
13	35.5	59.5	35.3	59.8	0.57	0.50
14	35.4	59.2	35.3	58.8	0.28	0.68
15	35.4	58.8	35.4	58.5	0.00	0.51
16	35.3	58.7	35.4	58.4	0.28	0.51
17	35.4	58.5	35.3	58.2	0.28	0.52
18	35.3	58.6	35.3	58	0.00	1.03
19	35.3	58.5	35.3	58.1	0.00	0.69
20	35.3	58.5	35.3	58	0.00	0.86

Fig. 10 shows that temperature and humidity are inversely proportional to each other. As the temperature

increases, the humidity decreases. This causes the humidity to differ slightly from the set of predetermined points, with a difference of 2% RH. In addition, the initial condition of humidity greatly affects the reach of the set point of humidity. Therefore, when testing is done from morning to afternoon, the set point will be reached and tends to be below the set point value, while when testing is done at night, the set point is reached but tends to be above the set point value. Comparison of testing to simulation and hardware testing the time needed to reach set points was faster on simulation testing, while close loop testing by Hardware was slower by 2 minutes for temperature and 3 minutes for humidity.

The designed devices will be tested by providing interference in the form of increased temperature, which aims to determine whether the system can maintain temperature and humidity conditions in the event of changes in temperature and humidity. The interference given to the system is an increase in temperature caused by lighting three candles. The testing with candle interference is shown in Fig. 11.

Interference testing is performed by waiting for the system to run until the temperature and humidity values are constant. Then light the candles to increase the temperature inside the cube. When the candle is turned on, the system is turned off. It aims to find out how much the temperature increases due to the lighting of candles. Once the interference temperature is felt to be maximum, the system will be turned on again. The results of the test are shown in Table V.

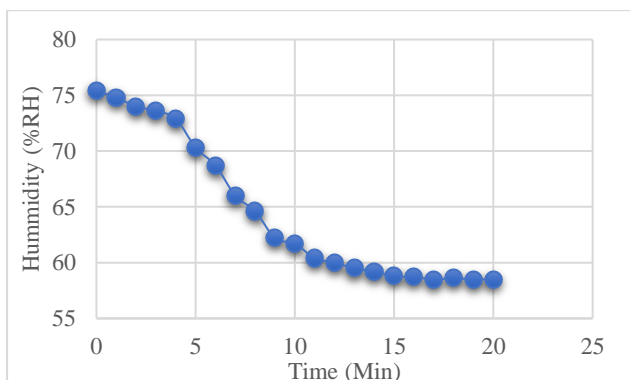
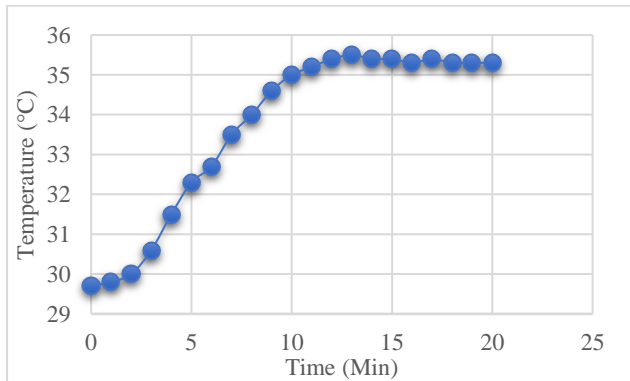

Fig. 10 Temperature Chart (a), Humidity Chart (b)

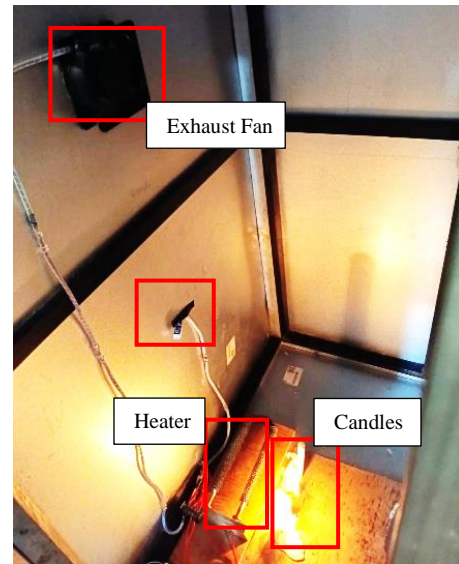

Fig. 11 Testing with candle interference

Table V shows the results of system integration testing with interference. The test was conducted for 28 minutes. In the ninth minute, the set point temperature had reached 35 °C. Humidity is 59.5% RH. After the 12th minute, the system was turned off, and three candles were inserted into the box. As a result, the temperature increased drastically to 38 °C, and the humidity dropped to 52% RH. Then, after the 18th minute, the system was re-enabled by keeping the candle on inside the cubicle box. As a result, the system is able to control temperature and humidity to 35.6°C and 59.6% RH. Integration testing chart with interference shown in Fig. 12.

TABLE. V Integration Test Result with candle interference

Time (Min)	Temp DHT22 (°C)	Hum DHT22 (%RH)
0	30.1	68.5
2	30.9	67.3
4	31.9	63.4
6	33.1	61.5
8	34.1	59.6
10	35	59.5
12	35.2	57
14	37	55.3
16	38.3	53.3
18	38.5	53.2
20	35.6	55.5
22	35.7	58.9
24	35.6	59.6
26	35.6	59.5
28	35.6	59.6

Fig. 12 shows that the temperature and humidity have been stable near the set point, but with the presence of such interference, a rather significant graphic change occurs. Temperatures rise to 58°C, while humidity drops to 53%

RH. Once the device is turned on again, the temperature and humidity will return to stable values close to the set point values. This shows that the designed device is able to condition the temperature and humidity according to the set point even if given interference.

Test data values are displayed on a 20x4 LCD and on a website using the Cayenne IoT platform. Cayenne IoT serves as a server that stores pre-designed control systems and is connected to microcontrollers. This submission of temperature and humidity data uses the ESP8266 module, which will be connected to the STM32 microcontroller. The data displayed on Cayenne IoT are temperature and humidity data. Cayenne IoT display shown in Fig. 13.

Fig. 13 shows data on integration testing with interference. Where the temperature is 34.5 °C and the humidity is 56% RH. Cayenne IoT can display actual temperature and humidity conditions. However, testing still has delays with those shown on the LCD.

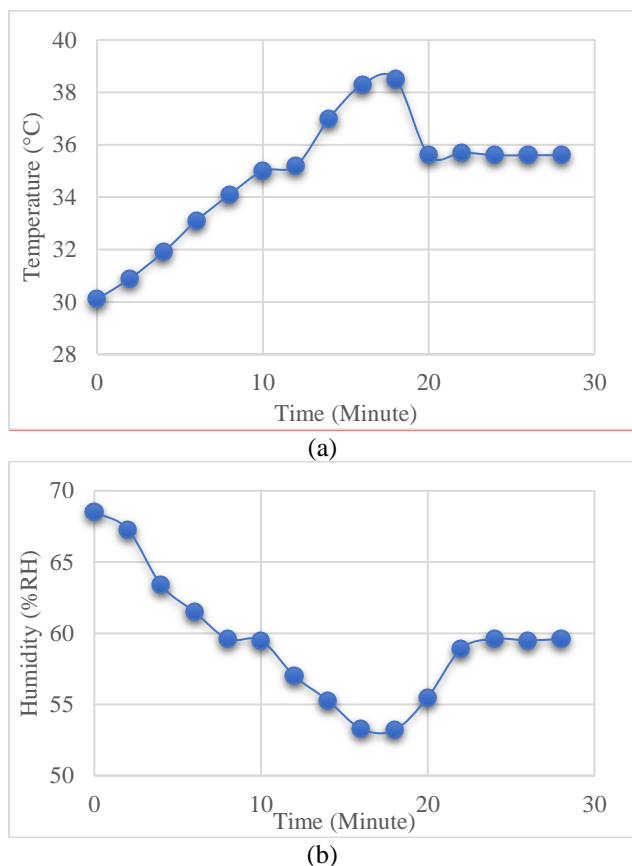

Fig. 12 Temperature chart with interference (a), Humidity chart with interference (b)

IV. CONCLUSION

In this paper, it can be concluded that a temperature and humidity control system with multiple inputs and multiple outputs fuzzy logic controller has successfully controlled temperature and humidity at 35 °C and 60% RH. The system has managed to maintain set point values despite interference from temperature increases. The fuzzy method used is capable of controlling the winding angles of both loads, namely the heater and exhaust fans. This

implementation of multiple inputs and multiple outputs fuzzy logic has performed well and resulted in only a small error of 0.55% for temperature and 1.05 for humidity. The test results can be displayed on the website using the Cayenne IoT platform.

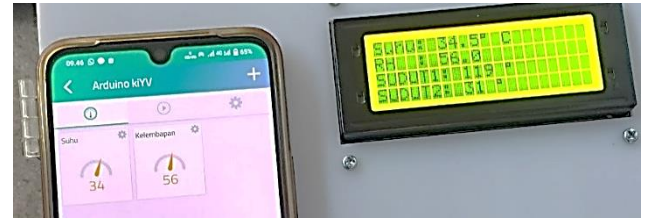

Fig. 13 Cayenne IoT

REFERENCE

- [1] A. Azam, M. Rafiq, M. Shafique, H. Zhang, M. Ateeq, and J. Yuan, "Analyzing the relationship between economic growth and electricity consumption from renewable and non-renewable sources: Fresh evidence from newly industrialized countries," *Sustain. Energy Technol. Assessments*, vol. 44, no. September 2020, p. 100991, 2021, doi: 10.1016/j.seta.2021.100991.
- [2] T. Lorde, K. Waithe, and B. Francis, "The importance of electrical energy for economic growth in Barbados," *Energy Econ.*, vol. 32, no. 6, pp. 1411–1420, 2010, doi: 10.1016/j.eneco.2010.05.011.
- [3] N. A. Salim, J. Jasni, and M. M. Othman, "Reliability assessment by sensitivity analysis due to electrical power sequential tripping for energy sustainability," *Int. J. Electr. Power Energy Syst.*, vol. 126, no. PA, p. 106582, 2021, doi: 10.1016/j.ijepes.2020.106582.
- [4] J. R. Riba, J. Martínez, M. Moreno-Eguilaz, and F. Capelli, "Characterizing the temperature dependence of the contact resistance in substation connectors," *Sensors Actuators, A Phys.*, vol. 327, 2021, doi: 10.1016/j.sna.2021.112732.
- [5] F. Capelli, J. R. Riba, and J. Sanllehi, "Finite element analysis to predict temperature rise tests in high-capacity substation connectors," *IET Gener. Transm. Distrib.*, vol. 11, no. 9, pp. 2283–2291, 2017, doi: 10.1049/iet-gtd.2016.1717.
- [6] J. R. Riba, A. G. Mancini, C. Abomailek, and F. Capelli, "A 3D-FEM-based model to predict the electrical constriction resistance of compressed contacts," *Meas. J. Int. Meas. Confed.*, vol. 114, pp. 44–50, 2018, doi: 10.1016/j.measurement.2017.09.003.
- [7] A. Carsimamovic, A. Mujezinovic, S. Carsimamovic, Z. Bajramovic, M. Kosarac, and K. Stankovic, "Calculation of the corona onset voltage gradient under variable atmospheric correction factors," *Proc. - EUROCON 2015*, pp. 1–5, 2015, doi: 10.1109/EUROCON.2015.7313697.
- [8] A. Carsimamovic, A. Mujezinovic, S. Carsimamovic, Z. Bajramovic, M. Kosarac, and K. Stankovic, "Analyzing of AC Corona Discharge Parameters of Atmospheric Air," *Procedia Comput. Sci.*, vol. 83, no. Seit, pp. 766–773, 2016, doi: 10.1016/j.procs.2016.04.165.
- [9] Y. Liu *et al.*, "Corona onset gradient of the bundle conductor on AC power lines under sand and dust weather condition at 2,200 m altitude," *J. Electrostat.*, vol. 95, no. July, pp. 32–41, 2018, doi: 10.1016/j.elstat.2018.08.004.
- [10] L. Yunpeng *et al.*, "Corona loss of the bundle conductors on EHV/UHV AC power lines under sandy and dusty conditions in high-altitude areas," *J. Electrostat.*, vol. 107, no. 619, p. 103476, 2020, doi: 10.1016/j.elstat.2020.103476.
- [11] E. Franceschi, M. Giorgi, G. Luciano, D. Palazzi, and E. Piccardi, "Archaeometallurgical characterisation of two small copper-based statues from the Cividale Museum (Friuli, Italy)," *J. Cult. Herit.*, vol. 5, no. 2, pp. 205–211, 2004, doi: 10.1016/j.culher.2003.07.004.
- [12] A. Fateh, M. Aliofkhazraei, and A. R. Rezvanian, "Review of corrosive environments for copper and its corrosion inhibitors," *Arab. J. Chem.*, vol. 13, no. 1, pp. 481–544, 2020, doi:

- 10.1016/j.arabjc.2017.05.021.
- [13] T. Wu, Z. Zhou, S. Xu, Y. Xie, L. Huang, and F. Yin, "A corrosion failure analysis of copper wires used in outdoor terminal boxes in substation," *Eng. Fail. Anal.*, vol. 98, no. April 2018, pp. 83–94, 2019, doi: 10.1016/j.engfailanal.2019.01.070.
- [14] A. Rahmadani, N. A. Windarko, and L. P. S. Raharja, "Rancang Bangun Sistem Monitoring Suhu dan Kelembapan serta Kendali Dua Heater pada Kubikel 20 kV Berbasis Sistem Informasi Geografis," *Maj. Ilm. Teknol. Elektro*, vol. 21, no. 2, p. 219, 2022, doi: 10.24843/mite.2022.v21i02.p09.
- [15] S. Soyguder, M. Karakose, and H. Alli, "Design and simulation of self-tuning PID-type fuzzy adaptive control for an expert HVAC system," *Expert Syst. Appl.*, vol. 36, no. 3 PART 1, pp. 4566–4573, 2009, doi: 10.1016/j.eswa.2008.05.031.
- [16] I. Gancliev, A. Taueva, K. Kutryanski, and M. Petrov, "Decoupling Fuzzy-Neural Temperature and Humidity Control in HVAC Systems," *IFAC-PapersOnLine*, vol. 52, no. 25, pp. 299–304, 2019, doi: 10.1016/j.ifacol.2019.12.539.
- [17] JM. He, W. J. Cai, and S. Y. Li, "Multiple fuzzy model-based temperature predictive control for HVAC systems," *Inf. Sci. (Ny)*, vol. 169, no. 1–2, pp. 155–174, 2005, doi: 10.1016/j.ins.2004.02.016